

MA-U

Isolating voltage measuring amplifier (5B)

Conditioned to voltage.

The measuring amplifier MA-U adjusts voltage signals to the 5V input of a PC data acquisition system. To emphasize is the extremely large bandwidth of 50kHz so that even slightest peaks of high-frequent signals do not remain undetected.

5B technology. Industrial standard.

The pin assignment of the 5B module corresponds to the 5B module standard of Analog Devices and Burr Brown. An additional 0EX pin has been introduced for sensors requiring unipolar supply to be suitable for connection.

You have the choice.

Four input voltage ranges from $\pm 0.5V$ to $\pm 10V$ are provided by the MA-U. DC voltage as well as AC voltage can be connected. Three filter cut-off frequencies for the output filter are provided.

Sensors well supplied.

To operate sensors, either an unregulated $\pm 12V$ DC supply or a regulated $+5V$ DC voltage or a $4mA$ current source for ICP sensors are provided.

Clearly safe.

If using several modules, the channels are galvanically isolated to each other and to the DAQ system. This perfectly protects the whole system against high potentials and interferences.

Undisturbed.

Common-mode interferences often produced by machinery or other loads are effectively suppressed by the balanced input of the differential amplifier. If an output filter is set, disturbing frequencies can be eliminated.

It's the setting that matters.

The selection of the measuring ranges, and the filter cut-off frequencies is done via DIP switches and soldering bridges. Offset and gain are adjustable with potentiometers.

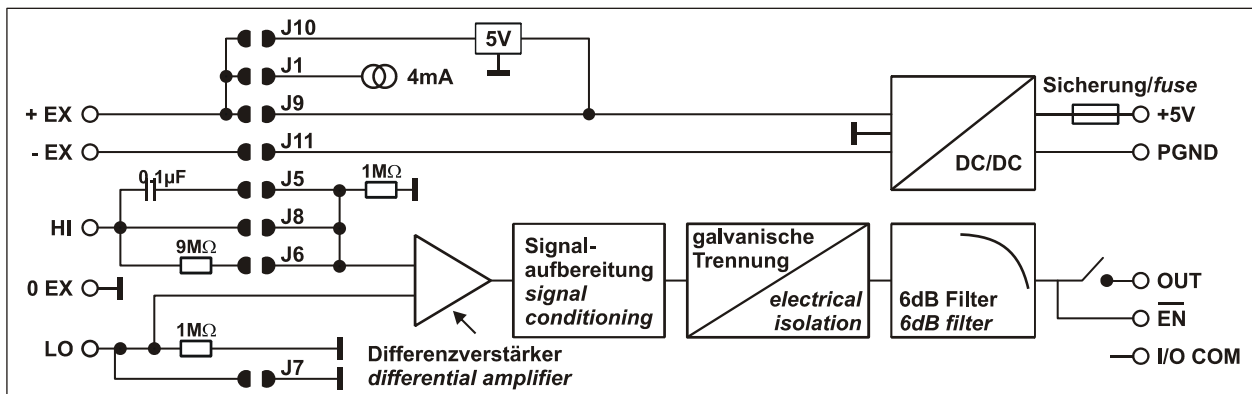

Functional diagram

1 Installation

For a tight installation, the 5B module is plugged into a backplane (AP series) or into an amplifier system (AMS series) from bmcme and fixed with a screw (see chapter 4.1).

The sensor or signal is attached to the relevant connector provided by the backplane or the amplifier system.

If the module is integrated in systems of other manufacturers (e.g. Analog Devices, Burr Brown), the additional 0EX pin (see chapter 2.4) introduced for special measuring applications and for screening purposes must be removed.

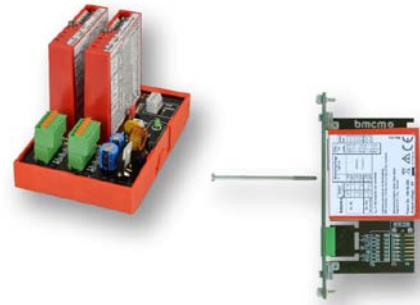

- Ensure that the settings of the DIP switches and the soldering bridges are correct (see chapters 0 and 2.3) before installing the modules.
- When inserting the modules, the power of the connection system must be turned off.

2 Connections, operating elements, and assignments

The connectors and operating elements are located on the front and back side of the 5B module.

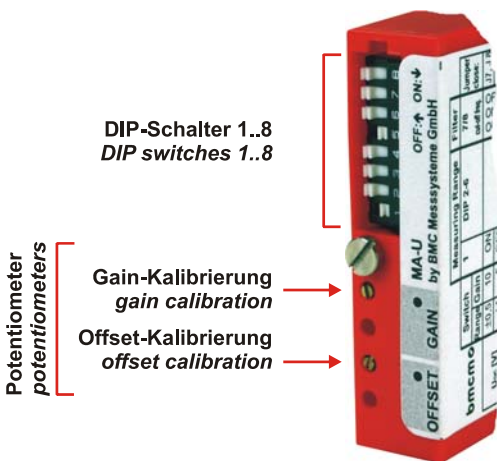

bmcme	Switch		Measuring Range		Filter	Jumper close:
	Range	Gain	1	DIP 2-6	7/8 cut-off freq.	
U _{DC} [V] (differential)	±0.5	10	ON	without function	OFF(7) + ON(8) = 1kHz; ON(7) + OFF(8) = 20kHz; ON(7) + ON(8) > 50kHz	J 8
U _{DC} [V] (non-differential)	±1	5	OFF			J 8
	±5	1	ON			J6, J7
	±10	0,5	OFF			J6, J7
U _{AC} [V _s] (DC decoupled)	±0.5	10	ON			J5, J7
	±1	5	OFF			J5, J7

U_{AC} is decoupled, not rectified.

Jumpers are placed at the bottom, DIP switches can be set on top of the module.

Not used jumpers must stay open. Adjusted at ±1V_{DC}. Test ok.

Patent No. 196 52 293
Output voltage: ±5V



Rev. 6.2

2.1 DIP switches

The amplification and filter cut-off frequency are selected with the DIP switches on the front of the measuring amplifier (see picture above).

DIP switch	Function
1	half measuring range / double amplification
2 - 6	(without function)
7 + 8	set filter cut-off frequency

The configuration table (see figure chapter 2), which is also provided on the module case, shows which DIP switches must be "ON" to set the desired configuration.

Example:

With the switch setting (switches white) in the figure on the right, 10-times amplification is reached. Depending on the jumper configuration, the input range is $\pm 500\text{mV}$ for DC voltage (J8 closed), or $\pm 100\text{mA}$ for DC current (J4, J8 closed).



The filter cut-off frequency is 50kHz.

2.2 Trim potentiometers

To calibrate the 5B module, offset and gain are adjusted at two trim potentiometers on the front side of the MA-U (see picture chapter 2).

The connected sensor is brought to the zero position first and the offset is adjusted at the module output. Then a known load is applied and the module is adjusted with the gain potentiometer at the output.



- The module is calibrated in the $\pm 10\text{V}$ measuring range ex works.
- Recalibration is required after changing the measuring range or the operation mode.

2.3 Solder jumpers

The solder bridges on the bottom of the module provide several functions. The configuration table (see figure chapter 2), which is also provided on the module case, shows which jumpers must be closed to set the desired configuration.

Jumper	Function
J10	+5V voltage source to +EX
J1	4mA current source to +EX (max. +12V)
J5	AC decoupling
J6	$\pm 50\text{V}$ measuring range (non-differential)
J7	LO to 0EX (input ground)
J8	HI direct input
J9	+12V EX
J11	-12V EX
J2, J3, J4, J12, J13	(without function)

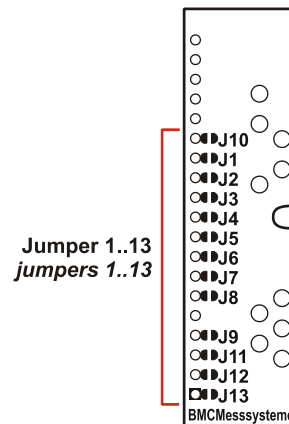

To prevent the modules from being damaged, close only jumpers required for the relevant application (see table chapter 2 and interfacing examples chapter 3). This applies especially to the power supply (close either J10 or J9 or J1!).

2.4 Connection pins

The following table and figure show the assignment of the connection pins of the measuring amplifier.

Pin	Assignment	Function
22	EN	enable input
20	OUT	output signal
19	I/O COM	output ground
17	+5V	+5V supply
16	PGND	power ground
7	0EX	0V potential of the input amplifier
6	HI	positive measuring amplifier input
5	LO	negative measuring amplifier input
4	+EX	positive supply voltage
3	-EX	negative supply voltage

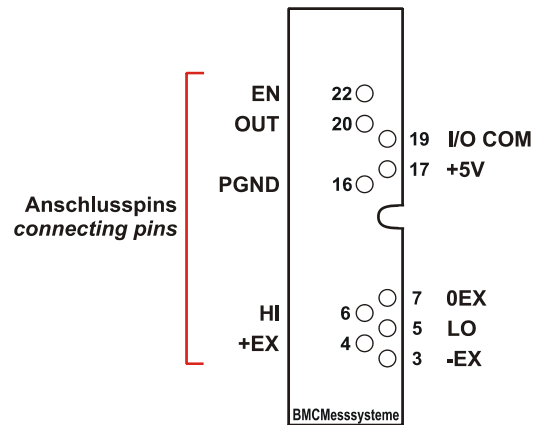

The pin assignment of the MA-U corresponds to the 5B modules of Analog Devices and Burr Brown. An additional 0EX pin (pin 7) has been introduced as reference for +EX and -EX. If using a non-bmcm backplane that does not provide a relating connection, this pin has to be removed. Then, however, a reference of the ±EX pins is only possible via the LO pin with J7 being closed. This is a specific assignment of BMC Messsysteme GmbH. The 0EX pin is not connected in modules of other manufacturers.

2.5 Output switch

The module features a semiconductor switch at the output, which is controlled by the enable input (EN, pin 22) with a TTL/CMOS level (also see figure chapter 2.4). It can also be activated with a switch, transistor, or optocoupler.



- The enable input (EN) of the module is low-active.
- If not used, the EN input must be connected to I/O COM (pin 19)!

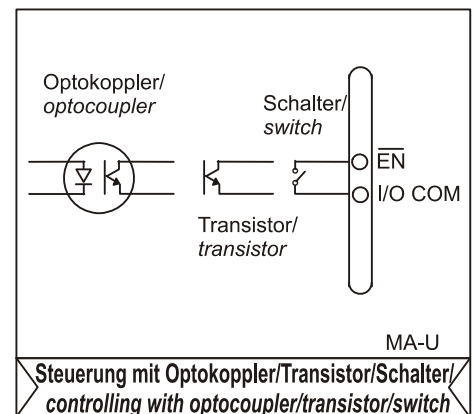

The output switch and EN have a reference to I/O COM. If the EN control signal is referred to PGND, a high-ohmic connection (e.g. 10kΩ) must be made between I/O COM and PGND (This influences the galvanic isolation between PGND and I/O COM!).

3 Interfacing examples

The module output is proportional to the input voltage in all operation modes and measuring ranges. Always use shielded cables. Apply cable shield at one end only. If earthing is required, connect the screen only at one end, otherwise there is a risk of hum pick-up.



All unneeded solder bridges must stay open!!

3.1 Voltage measurement (DC or AC decoupled)

The input is differential. For single-ended (non-differential) measurement, LO must be connected with 0EX (J6, J7 closed). In this operation mode, the input resistance R_i is $1\text{M}\Omega$.

Close J5 and J7 for AC decoupling (J8 open) removing DC components from the measuring signal. This operation mode exclusively works in single-ended mode because the connectable capacitor ($0.1\mu\text{F}$!) is only provided in the HI path (see functional diagram, page 1).

Extending the measuring range can always be achieved with an external voltage divider, of course.

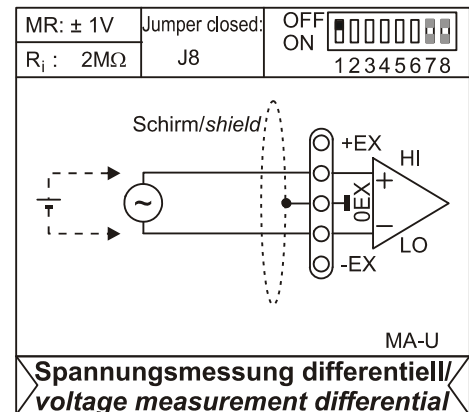

3.2 Sensor supply with +5V EX power source

The sensor is supplied with 5V (max. 30mA) constant voltage (J10 closed) and has a voltage output. The measuring input is non-differential.

Close J5 and J7 for AC decoupling (J8 open, only for $\pm 0.5\text{V}$ and $\pm 1\text{V}$ range). The AC part must be decoupled with an external capacitor (e.g. 100nF) in the $\pm 5\text{V}$ and the $\pm 10\text{V}$ range.

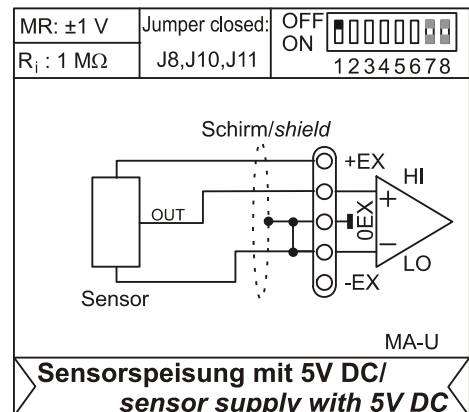

3.3 Sensor supply for Piezotron® sensors (Kistler)

The sensor is supplied with 4mA constant current (J1 closed) and changes its internal resistance. The measuring input is non-differential.

These sensors are operated with an AC decoupled amplifier input.

Close J5 and J7 for AC decoupling (only for ±0.5V and ±1V range).



The power supply (+5V) for the module must be stable. Voltage swings may otherwise influence the measuring signal.

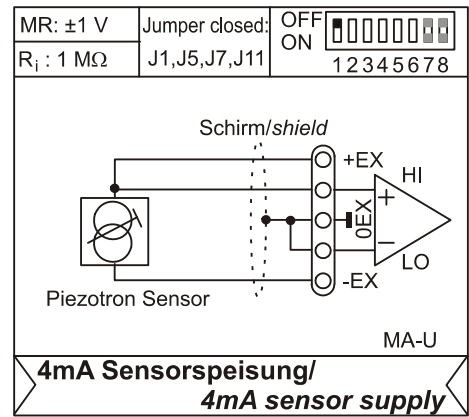

3.4 Sensor supply with ±12V EX power source

The module is a voltage module. The ± EX voltage is ±12V at 30mA and is unregulated (J9, J11 closed). It can be used for the supply e.g. of sensors or preamplifiers.

A sensor can also be supplied with only +12V at max. +40mA if being connected to 0EX. Open J9 and close J10 for +5V supply at +EX in relation to 0EX.

In case of a short circuit, the module is protected by a Multi-fuse, which regenerates app. 1 min. after interrupting the power supply.



Overload of the EX voltage will damage the module!

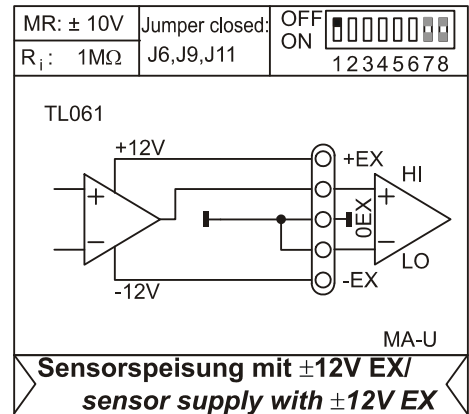

If the load of the EX voltage is very high, it may drop below ±12V resulting in the fact that the full ±10V measuring range cannot be used to its extend.

4 Supplementary products for MA-U

Amplifier systems and backplanes from bmcM allow the comfortable connection to the data acquisition system and the sensor supply. A variety different in size and design is available. The 5B modules can be used in any combination.

Further information about supplementary products is available on the website at www.bmcm.de/us.

4.1 Amplifier measurement systems (AMS series)

The AMS systems in robust aluminum housing are available as a 19" rack version (AMS84 series) or as a ½ 19" tabletop unit (AMS42 series) with or without integrated PC data acquisition system (USB or LAN).

The 5B measuring amplifiers are fixed on plug-in cassettes, which are mounted in the AMS device.

Various cassettes with different connectors on the bracket are available for individual sensor or signal connection.

The following AMS amplifier measurement systems from bmcM are available:



Product	Description
AMS42 / AMS84	amplifier measurement systems for 5B modules with 8/16 slots
AMS42/84-USB	amplifier measurement syst. for 5B modules, 8/16 slots, integrated DAQ system (USB)
AMS42/84-LAN16f	amplifier measurement syst. for 5B modules, 8/16 slots, integrated DAQ system (LAN)

4.2 Backplanes (AP series)

Up to eight (AP8a) or two (AP2a) 5B modules can be plugged into the backplanes. Sensors or signals are attached at terminal connectors.

The AP backplanes are suitable for DIN rail mounting.

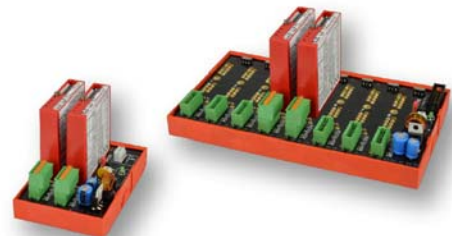

4.3 Other 5B modules (MA series)

The 5B measuring amplifiers from bmcM allow for the professional signal adjustment to a data acquisition system.

The amplifier output is ±5V or 0.5V. Most of the modules are electrically isolating and provide sensor supply.

The following 5B modules from bmcM are available:



Product	Description
MA-UNI	universal amplifier with galvanic isolation for U, I, R, thermocouple, strain gauge, LVDT
MA-UI	multi-range amplifier with galvanic isolation for U, I
MA-P09/12/15	power supply modules ±9V/ ±12V/±15V

5 Important notes for using the MA-U

- The module is only suitable for extra-low voltages - please observe the relevant regulations! The measuring amplifier must only be operated in closed housings (for reasons relating to EMC).
- All accessible pins are electrostatic sensitive devices. Provide for a grounded conductive work place. ESD voltages on open lines may cause malfunction. Only use an electrical isolated power supply unit (with CE).
- Only use non-solvent detergents for cleaning. The product is designed to be maintenance-free.
- As reference for the EX voltages or for screening purposes, a 0EX terminal was defined, which, however, can be removed if necessary. These EX voltages are not overload-proof.
- The amplifier is factory-balanced in the $\pm 10V$ range. Recalibration is required after changing measuring range or operation mode.
- Turn off the power before mounting the module into the backplane.
- If the fastening screw is fixed too tightly, the module or the backplane may be damaged.
- The module must not be used for safety-relevant tasks. With the use of the product, the customer becomes manufacturer by law and is therefore fully responsible for the proper installation and use of the product. In the case of improper use and/or unauthorized interference, our warranty ceases and any warranty claim is excluded.



Do not dispose of the product in the domestic waste or at any waste collection places. It has to be either duly disposed according to the WEEE directive or can be returned to bmcm at your own expense.

6 Technical data

(typ. at 20°C, after 15min., +5V supply)

• Measuring ranges

Gain:
Bandwidth at 6dB/oct. [kHz]:
Voltage DC [mV] // []:
Current DC [mA]:
 U_{drop} current range DC [mV]:

Measuring range 1	Measuring range 2	Measuring range 3	Measuring range 4
500	50	5	0.5
1	5	10	10
± 10	± 100	± 1000	$\pm 10V$
± 2	± 20	± 200	-
± 10	± 100	± 1000	-

At the output referring to: +5V .. -5V DC; Turning on DIP 1 reduces the respective measuring range to 50% (e.g. DIP 1 OFF: MR= $\pm 10V$; DIP 1 ON: MR= $\pm 5V$); Opening solder bridge J8 and closing J6+J7 extends the ± 10 measuring range \rightarrow Max. range possible (DIP 1 to ON!): $\pm 50V$.

* The module is factory-balanced in the $\pm 10V$ measuring range.

• Accuracy (typical)

Calibration:
Filter accuracy of f_g // Relative range accuracy:
Amplifier accuracy // Non-linearity:
Current shunt accuracy:
Temperature drift offset // gain:

offset: $\pm 10\%$; measuring range (gain): $\pm 10\%$
$\pm 15\%$ // 0.1%; if MR/2 typ. 1%; if MR= $\pm 50V$ typ. 2%
$\pm 0.1\%$ // $\pm 0.1\%$
$\pm 0.2\%$
typ. 100 ppm/°C, max 200ppm/°C // typ. 100 ppm/°C, max 200ppm/°C

The values for accuracy always relate to the respective measuring range. Errors might add at worst.

• Input range

Input resistance (voltage // current):
Voltage drop // Input suppressor circuit:
Input AC decoupling (with J5):
Excitation generation (electr. isolated):

single-ended: 1M Ω , differential: 2M Ω , turned off: 100k Ω // 5 Ω shunt
max. 1V // max. 240V AC for 1sec. (not in current measurement)
0.1 μF and 1M Ω for $f_g > 10Hz$
$\pm 12V$, $\pm 30mA$ unregulated or +5V, 30mA regulated or 4mA, $\pm 5\%$ power source, max. amplitude app. 20V

• Output range

Output voltage // Output load:
Output switch:
Output switching time // Switch resistance:
Output filter (switchable):
Supply sensitivity of the output:
Output hum/ripple:

$\pm 5V$ DC // $> 1k\Omega$, recommended $> 10k\Omega$ for 0.1% accuracy
CMOS switch with TTL-level or open collector switchable (low active)
10 μs at 200pF // typ. 50 Ω ; max. 100 Ω (short-circuit proof)
2-pole (12dB/oct) for 10kHz; 1-pole (6dB/oct) for 10Hz, 100Hz
typ. $\pm 5mV/V$
typ. 10mV _{ss} , max. 50mV _{ss}

• General data

Voltage supply (regulated):
CE standards:
ElektroG // ear registration:
Temperature ranges // Relative humidity:
Max. permissible potentials // Protection type:
Dimensions // Patent:
Delivery:
Available accessories:
Warranty:

+5V DC ($\pm 5\%$), 70mA, max. 250mA, protected by Multifuse
EN61000-6-1, EN61000-6-3, EN61010-1; for decl. of conformity (PDF) visit www.bmcm.de
RoHS and WEEE compliant // WEEE Reg.-No. DE75472248
operating temp. -25..50°C, storage temp. -25°C..+70°C // 0 - 90% (not condensing)
60V DC acc. to VDE , max. 1kV ESD on open lines // IP30
plastic housing 52 * 70 * 15mm // German patent no.:196 52 293
product, description
backplanes: AP2a, AP8a, AAB-II; AMS amplifier measurement systems
2 years from date of purchase at bmcm, claims for damages resulting from improper use excluded

Manufacturer: BMC Messsysteme GmbH. Subject to change due to technical improvements. Errors and printing errors excepted. Rev. 8.0 07/24/2013