



BP2

Backplane for MAL measuring amplifiers

For measuring amplifiers and sensors. Get connected.

Backplane for miniature amplifiers: Up to two measuring amplifiers, converters, or any other function modules can be integrated in the BP2/ BP2-BOX. If installed close to the signal, it provides for high interference resistance. Ideal for remote signal conditioning of passive sensors.

Signal conditioning in miniature format.

In type of construction, the cost-effective MAL modules are designed like a 24-pin DIL IC. Measurement applications can therefore be realized even in problematic locations. The great variety of available amplifier modules allows for the solution of the most individual measuring tasks - individual, compact, and simple.

Well supplied.

The BP2/BP2-BOX is operated with 9-40V. The supply voltage is connected via screw-clamp terminals. The integrated amplifiers are supplied by the electrically isolated power supply.

Signal connection. Clamp. Screw. Ready.

Sensors or other voltage signals can comfortably be connected via 4-pin spring terminal blocks.

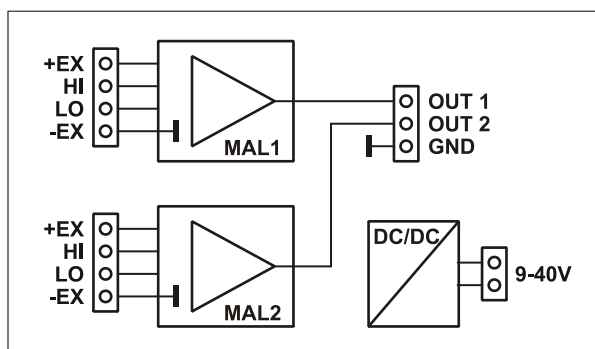

Functional diagram

Connection to the DAQ system.

The amplifier outputs are available at a 3-pin screw terminal connector. They are connected to the input lines of a data acquisition system. Combining the BP2/BP2-BOX with a measuring card or DAQ system from bmcm makes an extreme compact measurement system.

Temperature reference.

The BP2/BP2-BOX features an integrated sensor serving as temperature reference for thermocouple measurement.

DIN rail mounting.

The BP2 comes with a DIN rail carrier with bracket to be easily mounted on a standard DIN rail as commonly used in electrical installation.

Perfectly protected.

The BP2-BOX being accommodated in a waterproof IP65 housing is recommended for installation under rough environmental conditions.

The big option. You have the choice.

For all needing more channels: The backplane for miniature amplifiers is also available as a 16-channel version as external device (BP16).

1 Connections, pin assignments, and components

The available connections and different components of the BP2/BP2-BOX board are illustrated in the following figure of the board (view on top of the board (fitted with components), connectors down). All connectors on the board are accessible via screw terminals.

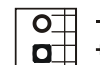

Figure 1

Amplifier slots, input terminals, and amplifier outputs with same numbering belong together. IN 1 and OUT 1, for example, are the connections for the measuring amplifiers of slot 1.

1.1 Power supply (DC)

The power supply is electrically isolated. 9-40V can be connected at a 2-pin screw terminal (see Figure 1). With sensors being attached, the power is max. 1.5W.



Check for correct poling of the power supply!

1.2 Input terminals (IN 1 / IN 2)

Two analog inputs are available at the LO and HI pins of the 4-pin terminals IN 1 and IN 2 to connect sensors or other voltage signals (see Figure 1).

Depending on the MAL amplifier used (see chapter 2), the +EX and -EX pins provide the power supply for connected sensors.

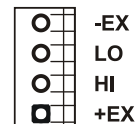

1.3 Analog outputs (OUT)

The two amplifier outputs are led out to a 3-pin screw terminal connector (see Figure 1). They are connected to the analog inputs of the data acquisition system.



1.4 Cold junction compensation (CJC)

A temperature sensor (LM35DZ, $\pm 1^\circ\text{C}$) between the input terminals of the BP2 / BP2-BOX serves as temperature reference for cold junction compensation during thermocouple measurement with MAL-THR.



1.5 Pin assignment of the amplifier slots

Each channel of the backplane can be equipped with miniature amplifiers of the MAL series from bmcm (see chapter 2) or compatible measuring amplifiers of other manufacturers. That means that all inputs can be adjusted to the most different signals and sensors. See the relevant data sheet about how to use the appropriate measuring amplifier.

The figure on the right shows the pin assignment of the MAL slot (view on top of the module backplane, see Figure 1).

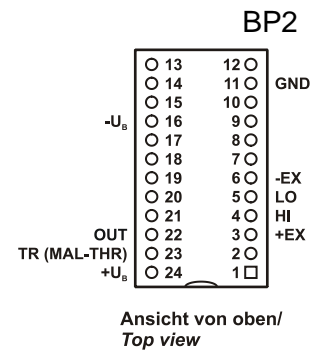

Pin	Name	Function
1, 2	n. c.	-
3	+EX	pos. sensor supply
4	LO	neg. signal input
5	HI	pos. signal input
6	-EX	neg. sensor supply
7, 8, 9, 10	n. c.	-
11	GND	power supply ground
12	n. c.	-

Pin	Name	Function
13, 14, 15	n. c.	-
16	-U _B	neg. supply (-12V)
17, 18, 19, 20, 21	n. c.	-
22	OUT	amplifier output ±5V
23	TR	temp. reference (only MAL-THR)
24	+U _B	pos. supply (+12V)

Change amplifiers only at no load! Check for correct poling (pin 1).

2 Available MAL amplifiers and connection technology (BP series)



A great variety of miniature measuring amplifiers with or without galvanic isolation is available. The backplanes of the BP series from bmcm differ in size and design and allow the comfortable connection to the data acquisition system and for the amplifier supply. The MAL measuring converters can be plugged on the backplanes in any combination.

As the current provided by the BP2/BP2-BOX is not unlimited, two MAL-SG2/5 amplifiers can only be used with strain gauge sensors featuring more than 250Ω in full-bridge circuit.

The following MAL modules and BP backplanes from bmcm are available:

Product	Description
MAL-ISO1/5/10/50	Galvanically isolating miniature amplifier for voltage ($\pm 1V/\pm 5V/\pm 10V/\pm 50V$)
MAL-ISO20mA	Galvanically isolating miniature amplifier for current ($\pm 20mA$)
MAL-FU	Frequency-voltage converter in miniature format
MAL-I20mA	Miniature amplifier for current ($\pm 20mA$), 5V sensor supply
MAL-PT100	Miniature amplifier for temperature (PT100, 0..300°C)
MAL-R1K	Miniature amplifier for resistance (0..1k Ω)
MAL-SG2/5	Miniature amplifier for strain gauge ($\pm 2mV/V$ or $\pm 5mV/V$)
MAL-THR	Miniature amplifier for temperature (thermocouple, type K, 0..1250°C)
MAL-U1/5/10	Miniature amplifier for voltage ($\pm 1V/\pm 5V/\pm 10V$), 5V sensor supply
BP16	16 slots, external device in aluminum housing, 5V sensor supply, connections: 2x Sub-D37
BP2	2 slots, for DIN rail mounting, 5V sensor supply, connections: screw terminals
BP2-BOX	2 slots, external device in IP65 box, 5V sensor supply, connections: screw terminals

3 Important notes for using the BP2/BP2-BOX

- The BP2/BP2-BOX is only suitable for extra-low voltages – please observe the relevant regulations!
- An electrically isolated power unit (with CE) must be used for power supply.
- All accessible pins are electrostatic sensitive devices. Provide for an earthed conductive work place when installing.
- For reasons relating to EMC the BP2/BP2-BOX must only be operated in closed housings.
- Sensors or signals are connected via screw terminals. Use screened cables! For good noise suppression connect the shield of the sensor lines at one end only. Close open inputs if possible. ESD voltages on lines may cause malfunction during operation.
- The ground of the BP2/BP2-BOX is electrically connected to the installed PC data acquisition system and also with the PC ground. Usually the ground of the PC is earthed, too. Be sure to avoid ground loops when connecting the sensors since they will cause measuring errors!
- Only use non-solvent detergents for cleaning. The product is designed to be maintenance-free.
- The board must not be used for safety-relevant tasks. With the use of the product, the customer becomes manufacturer by law and is therefore fully responsible for the proper installation and use of the product. In the case of improper use and/or unauthorized interference, our warranty ceases and any warranty claim is excluded.



Do not dispose of the product in the domestic waste or at any waste collection places. It has to be either duly disposed according to the WEEE directive or can be returned to bmcm at your own expense.

4 Technical data (typical at 20°C, after 5min., 9-40V supply)

• Electrical data

Power supply:	+9..40V DC, typ. 0.5W, max. 1.5W
Amplifier supply:	app. $\pm 12V$ (max. 40mA), isolated from the power supply
Max. permissible potentials:	60V DC acc. to VDE , max. 1kV ESD on open lines

• General data

Connections:	screw terminals (analog inputs: 2x 4-pin, analog outputs: 1x 3-pin, power supply: 1x 2-pin)
Temperature ranges:	operating temp. 0..70°C, storage temp. -25..70°C
Relative humidity:	0-90% (not condensing)
CE standards:	EN61000-6-1, EN61000-6-3, EN61010-1; for decl. of conformity (PDF) visit www.bmcm.de
ElektroG // ear registration:	RoHS and WEEE compliant // WEEE Reg.-No. DE75472248
Protection type:	BP2: IP00; BP2-BOX: IP65
Dimensions (L x W x H):	BP2: 65 x 45 x 35 mm ³ ; BP2-BOX: 100 x 85 x 35 mm ³
Delivery:	BP2: with DIN rail adapter; BP2-BOX: in plastic housing with 2 PG screws
Available accessories (optional):	miniature measuring amplifiers and converters of the MAL / MAL-ISO series; power supply ZU-PW40W (24V, 1.67A)
Warranty:	2 years from date of purchase at bmcm, claims for damages resulting from improper use excluded

Manufacturer: BMC Messsysteme GmbH. Subject to change due to technical improvements. Errors and printing errors excepted. Rev. 1.2 **13.10.2023**