



MA-P09/12/15
 Power supply modules (5B)

Sensors well supplied.

The extremely low-priced power supply modules MA-P09, MA-P12, and MA-P15 can be used for the supply of active sensors.

**5B technology.
 Industrial standard.**

The pin assignment of the 5B module corresponds to the 5B module standard of Analog Devices and Burr Brown. An additional OEX pin has been introduced for sensors requiring unipolar supply to be suitable for connection.

Powered by voltage or current.

The modules are available in three versions providing an unregulated supply voltage of $\pm 9V$ (MA-P09), $\pm 12V$ (MA-P12), or $\pm 15V$ (MA-P15) as well as a regulated $+5V$ DC voltage or a $4mA$ current source for ICP sensors. The power supply modules are not electrically isolated and have no output switch.

Clearly safe.

A Multifuse protects the module against overload. In this case, it is sufficient to interrupt the power supply. The Multifuse will be regenerated after one minute.

Compatibility.

The MA series provides a great variety of measuring amplifiers, measuring converters, or filter modules. They can be used in any combination allowing for the solution of the most individual measuring tasks.

Get connected.

With the backplanes (AP series) and amplifier systems (AMS series) for 5B modules varying in size and design, signal connection is easy.

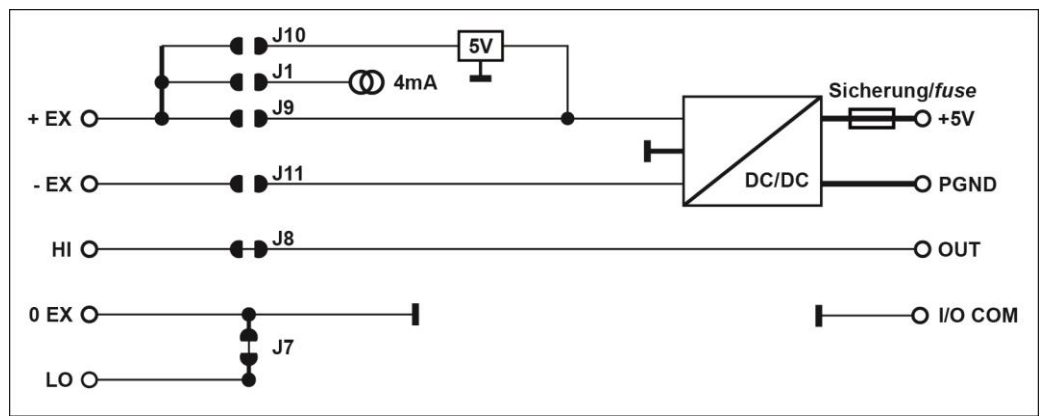

Function diagram

1 Installation

For a tight installation, the 5B module is plugged into a backplane (AP series) or into an amplifier system (AMS series) from bmcms and fixed with a screw (see chapter 5). The sensor is attached to the relevant connector provided by the backplane or the amplifier system.

If the module is integrated in systems of other manufacturers (e.g. Analog Devices, Burr Brown), the additional 0EX pin (see chapter 2.1) introduced for special measuring applications and for screening purposes must be removed.

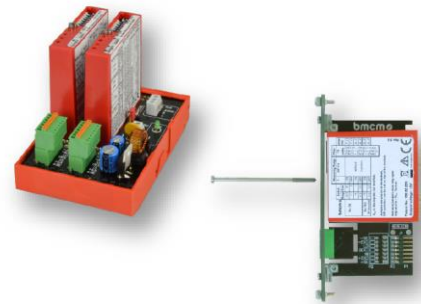

When inserting the modules, the power of the connection system must be turned off.

2 Solder jumpers

The solder bridges on the bottom of the module provide several functions.

Jumper	Function
J10	+5V voltage source to +EX
J1	4mA current source to +EX (MA-P09: max. 8.5V, MA-P12: max. 11.5V, MA-P15: max. 14.5V)
J7	LO to 0EX (input ground)
J8	HI direct input
J9	+12V EX
J11	-12V EX
J2, J3, J4, J5, J6, J12, J13	(without function)

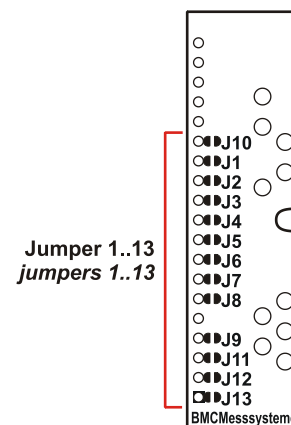

To prevent the modules from being damaged, close only jumpers required for the relevant application (see interfacing examples chapter 3). This applies especially to the power supply (close either J10 or J9 or J1!).

2.1 Connection pins

The following table and figure show the assignment of the connection pins of the measuring amplifier.

Pin	Assignment	Function
22	EN	enable input
20	OUT	output signal
19	I/O COM	output ground
17	+5V	+5V supply
16	PGND	power ground
7	0EX	0V potential of the input amplifier
6	HI	positive measuring amplifier input
5	LO	negative measuring amplifier input
4	+EX	positive supply voltage
3	-EX	negative supply voltage

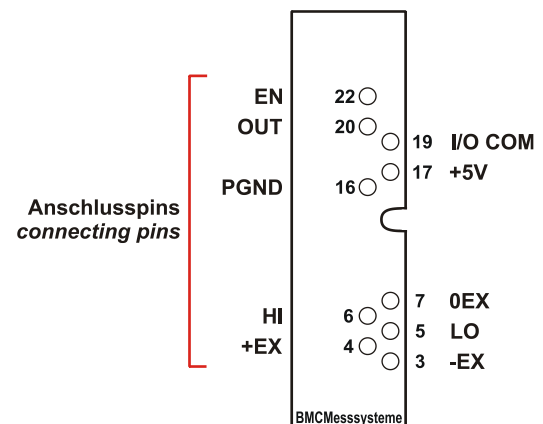

The pin assignment of the MA-P09/12/15 corresponds to the 5B modules of Analog Devices and Burr Brown. An additional 0EX pin (pin 7) has been introduced as reference for +EX and -EX. If using a non-bmcm backplane that does not provide a relating connection, this pin has to be removed. Then, however, a reference of the \pm EX pins is only possible via the LO pin with J7 being closed.

This is a specific assignment of BMC Messsysteme GmbH. The 0EX pin is not connected in modules of other manufacturers.

3 Interfacing examples: Supply with $\pm 9V/\pm 12V/\pm 15V$ EX

The \pm EX voltage is $\pm 9V/\pm 12V/\pm 15V$ at 30mA and is unregulated (J9, J11 closed). It can be used for the supply e.g. of sensors or preamplifiers.

The measurement signal is directly led through from HI to OUT.

In case of a short circuit, the module is protected by a Multifuse, which regenerates app. 1 min. after interrupting the power supply.

Always use shielded cables. Apply cable shield at one end only. If earthing is required, connect the screen only at one end, otherwise there is a risk of hum pick-up.

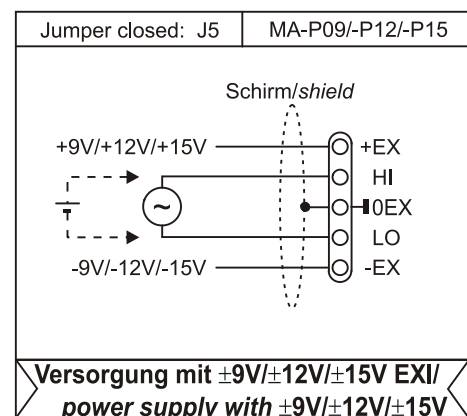

- **Overload of the EX voltage will damage the module!**
- **All unneeded solder bridges must stay open!!**

4 Supplementary products for MA-P09/12/15

Amplifier systems (AMS series) and backplanes (AP series) from bmcm allow the comfortable connection to the data acquisition system and the sensor supply.

A variety different in size and design is available.

The 5B modules (MA series) can be used in any combination.

Further information about supplementary products is available on the website at www.bmcm.de/us.



5 Important notes for using the MA-P09/12/15

- The module is only suitable for extra-low voltages - please observe the relevant regulations! The measuring amplifier must only be operated in closed housings (for reasons relating to EMC).
- All accessible pins are electrostatic sensitive devices. Provide for a grounded conductive work place. ESD voltages on open lines may cause malfunction. Only use an electrical isolated power supply unit (with CE).
- Only use non-solvent detergents for cleaning. The product is designed to be maintenance-free.
- As reference for the $\pm 9V/\pm 12V/\pm 15V$ EX voltages or for screening purposes, a 0EX terminal was defined, which, however, can be removed if necessary. These EX voltages are not overload-proof.
- Turn off the power before mounting the module into the backplane.
- If the fastening screw is fixed too tightly, the module or the backplane may be damaged.
- The module must not be used for safety-relevant tasks. With the use of the product, the customer becomes manufacturer by law and is therefore fully responsible for the proper installation and use of the product. In the case of improper use and/or unauthorized interference, our warranty ceases and any warranty claim is excluded.



Do not dispose of the product in the domestic waste or at any waste collection places. It has to be either duly disposed according to the WEEE directive or can be returned to bmcm at your own expense.

6 Technical data

(typ. at 20°C, after 15min., +5V supply)

• General data

Excitation generation:
Voltage supply (regulated):
CE standards:
ElektroG // ear registration:
Temperature ranges:
Relative humidity:
Max. permissible potentials:
Protection type:
Dimensions:
Delivery:
Available accessories:
Warranty:

	$\pm 9V/\pm 12V/\pm 15V$, 2W unregulated (no overload protection) or +5V regulated or 4mA
	+5V DC ($\pm 5\%$), 50mA, max. 250mA, protected by Multifuse
	EN61000-6-1, EN61000-6-3, EN61010-1; for decl. of conformity (PDF) visit www.bmcm.de
	RoHS and WEEE compliant // WEEE Reg.-No. DE75472248
	operating temp. -25..50°C, storage temp. -25°C..+70°C
	0 - 90% (not condensing)
	60V DC acc. to VDE, max. 1kV ESD on open lines
	IP30
	plastic housing 52mm x 70mm x 15mm
	product, description
	backplanes: AP2a, AP8a, AMS amplifier measurement systems
	2 years from date of purchase at bmcm, claims for damages resulting from improper use excluded