

■ USB-AD-OEM

USB DAQ Device

Really Simple.

Record and output signals with the USB-AD: The USB data acquisition system is ideal for universal applications in measurement and control technology. Implement your own ideas – just plug in and head off!

OEM. Compact. Powerful. Budget Price.

The idea behind the USB-AD-OEM: measuring where there is very little space. Mounting holes like 2,5" HD/SSD mean, you can mount the USB-AD-OEM in a PC or any other housing.

16 In. 1 AOut. 12 Bit. $\pm 5V$.

Voltage signals in the $\pm 5V$ range are connected to 16 analog inputs. The sampling takes place with 12 bit resolution and up to 160Hz total sampling rate. Analog controls are possible with the analog 12-bit output in the $\pm 5V$ output range.

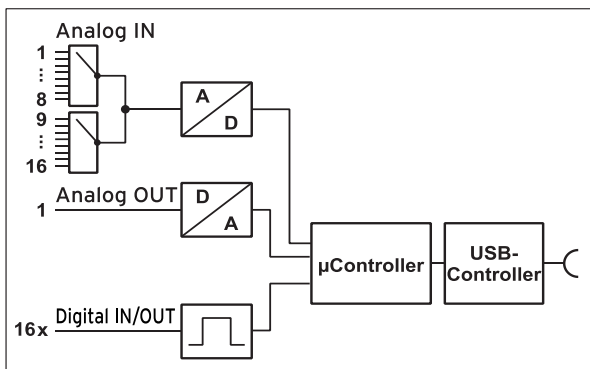

Functional Diagram

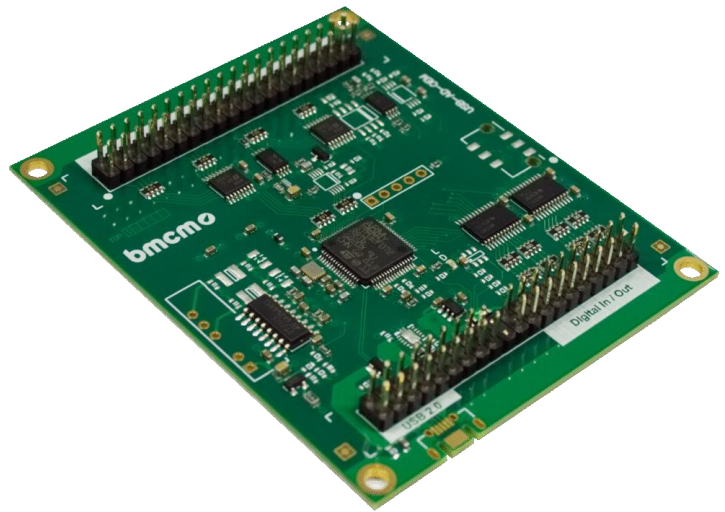

16 Digital In-/Outputs.

Digital states can be recorded or controlled in 16 digital inputs and outputs. The direction of the digital lines can be selected in groups of 8.

Plug & Play.

The connection to the PC happens via USB. That way the USB-AD-OEM uses all USB-typical features (eg. Plug & Play, Hot-Plug). Up to 127 devices can be connected and installed during operation.

Powered by USB.

The device is powered by the USB interface. This reduces the wiring effort to a minimum.

Optimal for Windows.

The drivers and programming interface is optimized for 64Bit under Windows® 10/11. All software for installation and programming of the USB-AD-OEM is included free of charge.

NextView®. Try For Free.

The device is supported by NextView®, the software for measurement data acquisition and analysis. A fully functional 14-day trial version is included in the scope of delivery. This allows the functionality of the USB-AD-OEM to be tested directly.

1 Start-up procedure

All available software and documentation for the USB-AD are located on www.bmcm.de/usb-ad-oem-en in the tab **Downloads**.

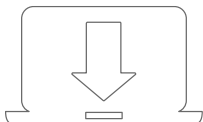

1. Step: Installation device driver

Install the latest driver package in order to use the USB measurement device. You will find the package on www.bmcm.de/usb-ad-oem-en in the tab **Downloads** in the category **BMCM – Drivers**.



2. Step: Connect up

Connect the provided USB cable to the device and to a free USB port of the PC. Then start the plug and play installation. The device gets its power supply through the USB connection.

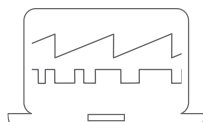

3a. Step: Measuring with NextView

To be able to use your measurement system with NextView, you just need to download and install the latest version of NextView on <http://www.nextview.de/go-en>. In case you did not buy NextView, request a free of charge trial version when first starting NextView. Find more information about NextView and its installation on www.nextview.de.

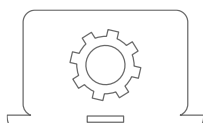

3b. Step: Measuring with API

In case you want to use the measurement device without NextView, you need to download and install the free of charge programming interface LIBAD4. You can find this on www.bmcm.de/usb-ad-oem-en in the tab **Downloads** in the category **LIBAD – Programming Interface (API)**, too. Find more information on www.bmcm.de/libad-en.

1 Getting Started

Please install the drivers package by bmcm first. Then connect the USB cable of the USB-AD-OEM to a free USB sport of the PC. The power is supplied via the USB connection. Now you can install other software components if needed.

2 Pin Assignment Analog In/Out

Das USB data acquisition system features 16 analog inputs with a measurement range of +/-5V and an analog output in the range of +/-5V. Signals are connected via a 40-way pin connector:

40way pin conn.	Assignment
1	Aln 1
3	Aln 2
5	Aln 3
7	Aln 4
9	Aln 5
11	Aln 6
13	Aln 7
15	Aln 8
17	Aln 9
19	Aln 10
21	Aln 11
23	Aln 12
25	Aln 13
27	Aln 14
29	Aln 15
31	Aln 16
35	AOut 1
37	-
2 .. 40	AGND

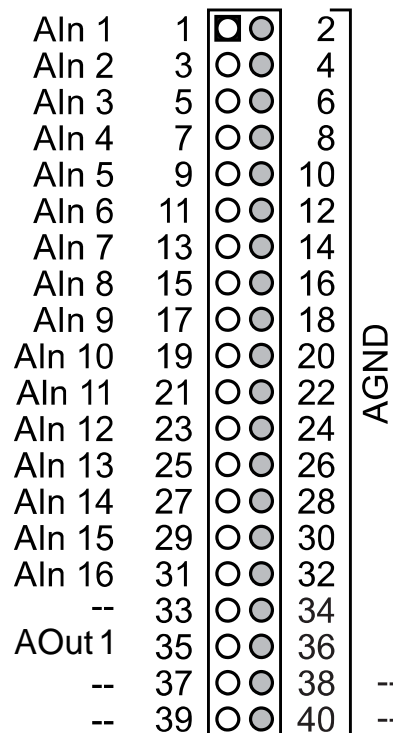

The maximum potentials versus ground must not exceed ±7V. In the event of overload on one channel, all other channels can also display incorrect values.

AGND and DGND are connected to the mass of the PC.

2 Pin Assignment Digital I/O & USB

16 digital Lines can be used as digital in- and outputs (*low*: 0V..0,7V; *high*: 3V..5V). The switch over happens in groups of 8. The auxiliary voltage is available at pin 17 and 18. Signals are connected via a 40-way pin connector:

40way pin conn.	Assignment
1	B1
2	B2
3	B3
4	B4
5	B5
6	B6
7	B7
8	B8
9	A1
10	A2
11	A3
12	A4
13	A5
14	A6
15	A7
16	A8
17	Vext
18	Vext
19	DGND
20	DGND
21 ... 31	--
32	Vusb
33	--
34	D-
35	--
36	D+
37	--
38	DGND
39, 40	--

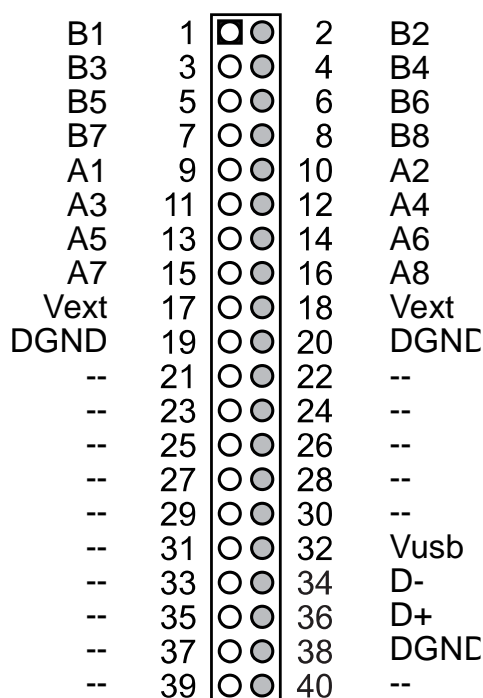

- The lines B1 .. B8 are set as output and A1 .. A8 as input in the default state.
- The digital in- and outputs are protected with 33Ω resistors. An input voltage outside the permitted voltage range of 0V..5V may damage the device.
- • The connections Vext provide an auxiliary voltage in the range of 4..5V. This is protected by a fuse (10mA).
- • A cable available from a computer retailer can be used to connect the USB line. Please check that the assignment is correct..

3 Building In and Mechanics

The measuring system is supplied as an open circuit board. Please note not to have any electrical connections to other components such as housing and cables during installation and operation.

The board is equipped with four holes in the corners. It can be fastened in a housing via bolts. The hole spacing corresponds to the position of common HDD / SSD 2.5 "mounting holes (M3).

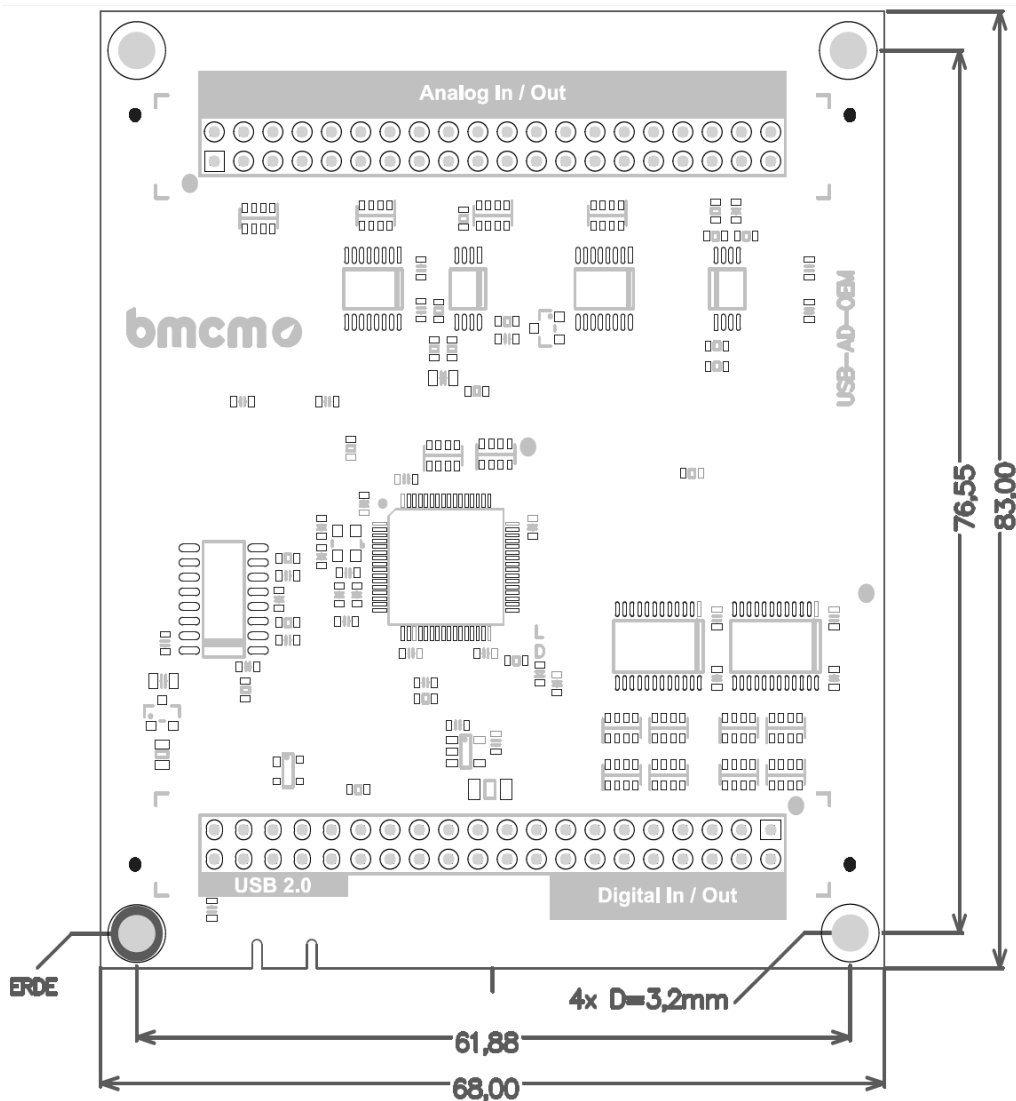

Connect the pad labeled EARTH to the housing earth (functional earth).

4 Interfacing Examples

4.1 Interfacing Examples for Digital Inputs

The digital lines are wired with a serial resistor of 33Ω and a pull-down resistor of $100k\Omega$.

4.1.1 Connecting an Optocoupler

Optocouplers provide optimum protection at each input line. With them, it is possible to connect higher voltages and to protect the hardware from being destroyed. In this regard, please also see application examples of the optocoupler you use.

Optocoupler cards (ID:OR8) featuring 8 inputs are available at bmc.

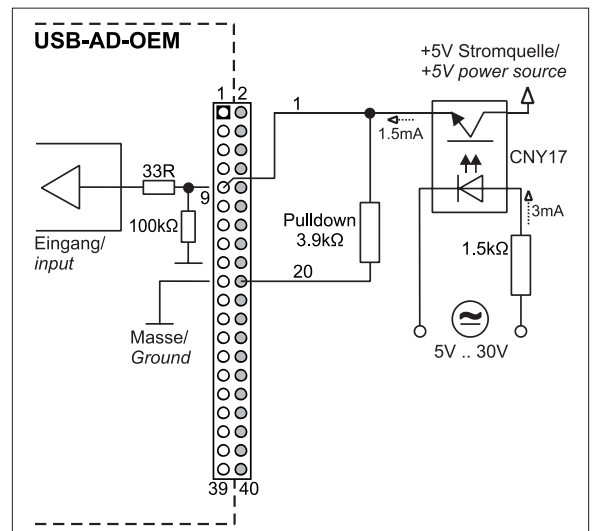

4.1.2 Connecting a Push-Button / Switch

Please make sure to use a push-button with debounce protection, because otherwise several pulses might be recorded.

The 3.9kΩ pull-down resistor is optional in order to create a defined low signal even with long lines.

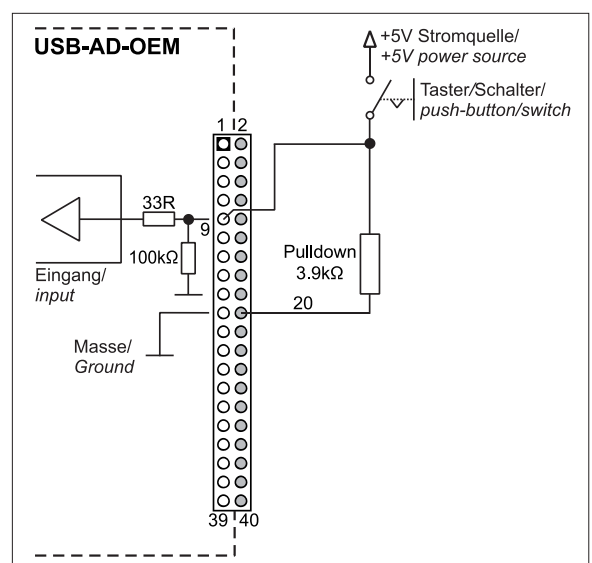

4.1.3 Connecting a Voltage Divider

If connecting a DC voltage higher than 5V, a voltage divider must be used so that 5V at the maximum are applied at the device input. Exceeding the 5V input voltage might cause damages to the device.

The relation between the two resistors to be used is calculated with the following formula:

$$U/U_1 = (R_1 + R_2) / R_1$$

Input voltages less than 5V are also sufficient (*high* ≥ 3V).

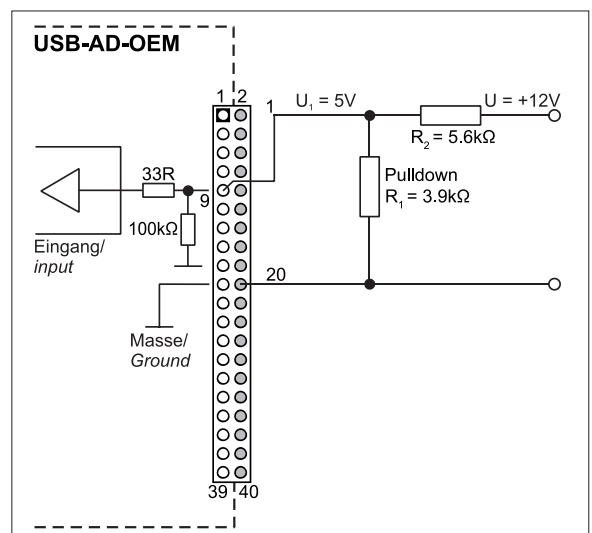

4.2 Anschaltbeispiele für digitale Ausgänge

The digital lines are wired with a serial resistor of 33Ω and a pull-down resistor of $100k\Omega$.

4.2.1 Connecting an LED

Only so-called low-current LEDs can be used, because they already work with 1mA current.

When using standard LEDs, the dropping resistor has to be adjusted accordingly.

Please also observe the total current listed in the technical data (see chapter 3).

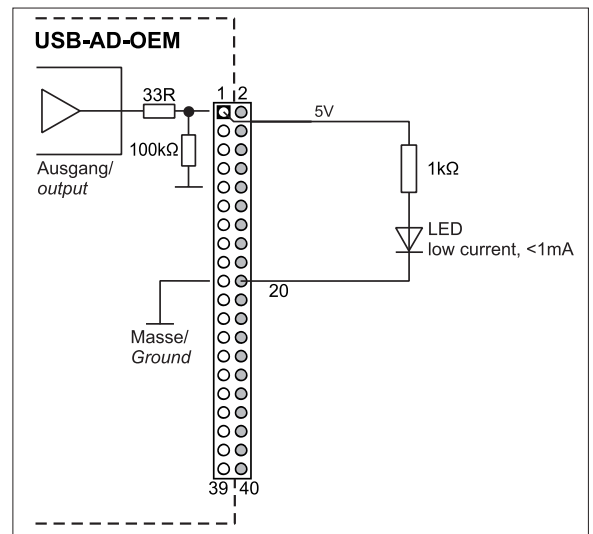

4.2.2 Connecting a Relay

A connected relay is ideal to switch higher currents. Since the field coil of the relay requires a higher current than provided by the measurement system at one line, a transistor is connected ahead.

Relay cards featuring 8 outputs are available at bmc.

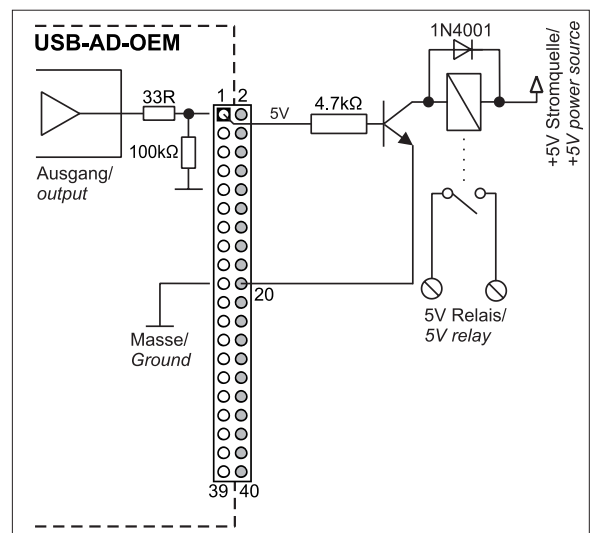

4.2.3 Connecting a Lamp

A transistor can be used to switch higher loads. The selected transistor must comply with the maximum switchable current.

The figure on the right shows an application with a maximum current of 100mA .

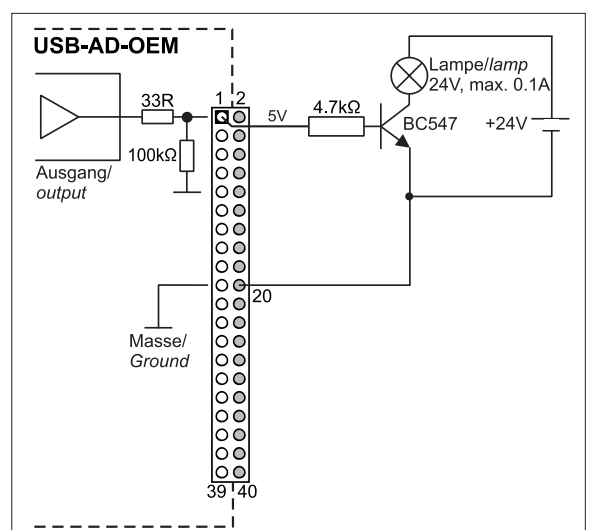

5 Important Notes for Using the USB-AD-OEM

- The device is only suitable for extra-low voltages – please observe the relevant regulations! Only use the device with housing closed. ESD voltages at open lines may cause malfunction.
- Only use non-solvent detergents for cleaning. The product is designed to be maintenance-free.
- Signal cables are connected at the 40-way pin connector – preferably use shielded cables. For best possible interference suppression, connect shield at one end only. Close open inputs if necessary.
- Connect the earth of the board with the functional earth. Be sure to avoid ground loops since they will cause measuring errors!
- PCs (notebooks) which are not grounded often produce high potentials to earth at the USB socket so that safe operation cannot be guaranteed. Connect the measuring system to earth in this case.
- The gain is adjusted to even values. Therefore, only 4000 values (for 12 bit) of the full range of the converter are used. As a result, the measuring ranges are slightly larger (e.g. ±5.12V) than the indicated measuring ranges so that overranges can be recognized. The AD converter of the USB-AD-OEM has a code noise of up to ±1 LSB
- The device must not be used for safety-relevant tasks. With the use of the product, the customer becomes manufacturer by law and is therefore fully responsible for the proper installation and use of the product. In the case of improper use and/or unauthorized interference, our warranty ceases and any warranty claim is excluded.

 Do not dispose of the product in the domestic waste or at any waste collection places. It has to be either duly disposed according to the WEEE directive or can be returned to bmcm at your own expense.

3 Technical Data (typical at 20°C, after 5min., +5V supply)

• Analog Inputs

Channels // Sampling rate

Surge protection:

Input resistance // Input capacity:

Zero shift // Gain drop:

16 single-ended // up to 10 values/second per channel can be sampled (depending on software and PC)			
max. ±12V (when turned on), max. ±7V (when turned off), max. ±20mA in total of all input channels!			
1MΩ (with PC turned off: 1kΩ) // 5pF			
±50ppm/°C // ±50ppm/°C			
Measurement range	Resolution	abs. accuracy	typ. noise
±5V	12 Bit (2,5mV)	±5mV	±1 LSB

Accuracy:

The values for accuracy always relate to the respective measuring range. Errors might add at worst.

• Analog Output

Voltage range // Output current:

Resolution // Accuracy:

Zero shift // Gain drop:

1 voltage output with ±5V // 1mA max.	
12 bit // typ. ±4 LSB, max. ±20 LSB	
±50ppm/°C // ±50ppm/°C	

• Digital Inputs/Outputs

Channels // Level:

Input resistance:

Current pick-up per output pin:

Surge protection:

16 digital lines // CMOS/TTL compatible (low: 0V..0.7V; high: 3V..5V)	
min. 1MΩ (with PC turned off: 1kΩ)	
25 mA per pin; 50 mA per pin	
max. ±5.5V, protected with 33Ω	

• General Data

Power supply:

USB interface:

Connections (analog + digital):

CE standards:

ElektroG // ear registration:

Max. permissible potentials:

Temperature ranges:

Relative humidity:

Dimensions:

Delivery:

Available accessories (optional):

Warranty:

+4.5V..+5.5V from USB connection to the PC, max. 100mA	
USB 2.0 compatible (full speed)	
2x40way pin connectors (RM2,54)	
EN61000-6-1, EN61000-6-3, EN61010-1; for decl. of conformity (PDF) visit www.bmcm.de	
RoHS and WEEE compliant // WEEE Reg.-No. DE75472248	
60V DC acc. to VDE, max. 1kV ESD on open lines	
-25°C..+70°C	
0-90% (not condensing)	
83 x 68x x13 mm3	
circuit board	
USB cable	
2 years from date of purchase at bmcm, claims for damages resulting from improper use excluded	

• Software

Software free of charge download:

NextView (optional):

LIBAD4 SDK for C/C++ programming on Windows® 10/11;	
trial version of the measuring software NextView® to test and operate the hardware	
professional software (versions: Professional, Lite) for the acquisition and analysis of measurement data on Windows®10/11	